

FEATURES OF BERM BREAKWATERS AND PRACTICAL EXPERIENCE

by

Jørgen Juhl, Senior Engineer
Danish Hydraulic Institute
Denmark

and

Ole Juul Jensen, Head of Marine Structures Department
COWIconsult
Denmark

ABSTRACT

This paper describes the features of berm breakwaters including advantages and drawbacks in comparison to traditional rubble mound structures. A review of selected practical experience with eight berm breakwaters is described in terms of typical cross-sections and key parameters (two examples from Norway, Iceland and USA, and one from Faroe Islands and Australia). In three of the cases described, prototype measurements of the profile development of the berm are available, and for two of these a comparison with model tests is shown. The paper includes discussions and examples of required quality assurance programmes for construction of berm breakwaters.

1 INTRODUCTION

In principle two different types of rubble mound breakwaters exist, ie conventional rubble mound breakwaters with or without a crown wall and berm breakwaters. The main armour layer of a conventional rubble mound breakwater is designed for limited damage (statically stable), whereas for a berm breakwater the berm reshapes into a flatter and more stable profile. The more stable reshaped profile of a berm breakwater is the basic idea of the S-shaped breakwater, which initially is built with a flatter statically stable slope around still water level. In **Figure 1**, typical cross-sections of the three mentioned types of rubble mound breakwaters are shown. Further, a number of hybrids of conventional and berm breakwaters exist, eg conventional rubble mound breakwaters with a small berm or increased armour layer thickness.

Berm breakwaters have unconsciously been known since the middle of the nineteenth century, but increasing attention has been paid to this type of breakwater during the last 10 to 15 years. To the authors' knowledge, the interest in newer times on this type of structure started in 1978 when the Danish Hydraulic Institute developed a berm breakwater alternative for Skopun Harbour, Faroe Islands (Jensen and Sørensen (1987)). Many of the early breakwater structures were constructed by simply dumping quarried stones, which were available at the site, into the sea. Material was placed until a stable breakwater profile was reached, and after severe damage repair was carried out by simply adding more stone material. A few examples of these early berm breakwaters, of which some still exist, are shown in **Figure 2**.

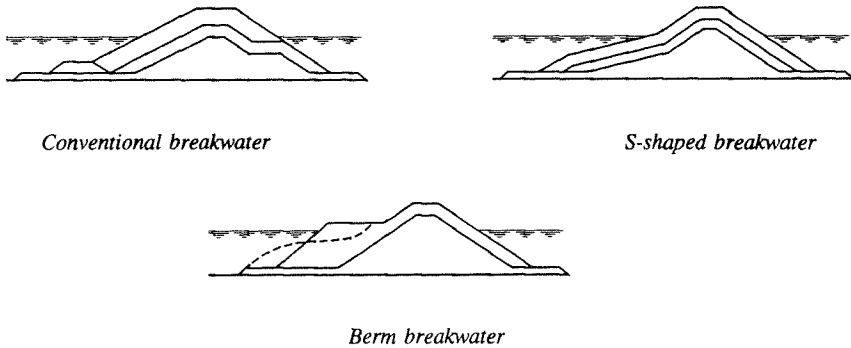

Figure 1 Typical cross-sections of three types of rubble mound breakwaters.

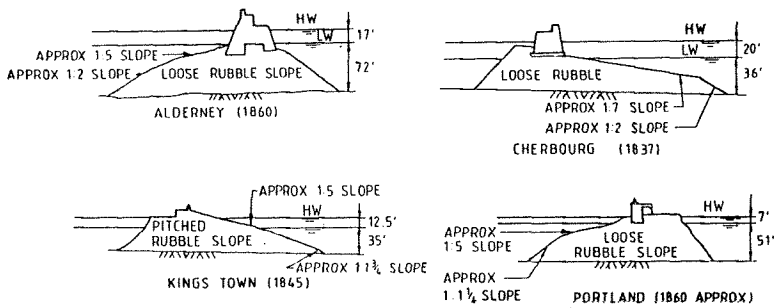

Figure 2 Examples of historical berm breakwaters (Figure from Hall (1987)).

In literature, various synonyms have been used for a berm breakwater, ie dynamically stable breakwater, unconventional breakwater, reshaping breakwater, naturally armouring breakwater and mass armoured breakwater. However, it is important to distinguish between berm breakwaters which reshape into a statically stable profile or dynamically stable profile.

The paper describes the features of berm breakwaters and points out both advantages and present drawbacks compared to conventional rubble mound structures. Eight recently constructed berm breakwaters are described in terms of typical cross-sections and key parameters. In a few cases results from model tests are included. In three of the described cases, prototype measurements of the profile development of the berm are available, and for two of these a comparison with model measurements is shown.

2 FEATURES OF BERM BREAKWATERS

A berm breakwater is a rubble mound breakwater with a berm above still water on the seaward side. During exposure to wave action of a certain intensity, the berm reshapes until eventually an equilibrium profile of the stones on the seaward face is reached. For each wave height, there is thus an equilibrium profile corresponding to this wave height. A typical berm breakwater profile

is shown in Figure 1. Just below the water level the reshaped profile has typically a slope of about 1:5. In front of this flat slope, stones are deposited with a steeper slope approaching the natural angle of repose. Wave energy is dissipated in the mass of stones in the flat slope resulting in reduced wave run-up above still water level where the natural equilibrium slope is steeper.

Berm breakwaters can be designed to be in either static or dynamic equilibrium in the long-term. For a dynamically stable berm breakwater the stones are allowed to move somewhat but with the average profile being in equilibrium. In order to ensure long-term stability, berm breakwaters should reshape into a statically stable profile where movements are only occurring in very severe and rare conditions. This requirement is due to the fact that frequent stone movements could result in abrasion and fracturing or displacement of stones finally resulting in degradation of the breakwater.

A berm breakwater trunk section exposed to oblique waves has to be designed with stones larger than a certain critical size in order to avoid continued movements of stones in the wave direction (longshore transport) which would eventually endanger the breakwater.

Singular points are of special interest for berm breakwaters, eg bends and roundheads. Stone displacements occurring at singular points result in stones being moved in the wave direction and the structure is consequently weakened. A point of special concern is whether, and under which conditions, a singular point of a berm breakwater may develop in a way that in the long-term will lead to structural failure. For a permanent structure, such features are normally undesirable as it would require maintenance from time to time in order to ensure the long-term stability.

The average armour rock size needed in a berm breakwater structure is smaller than in a traditional rubble mound structure. This is due to the flatter final slope of the seaward face on which the breaking wave plunges and dissipates energy, and the higher proportion of wave energy dissipated within the porous mound (reducing the hydrodynamic forces acting on the individual stones). Further, wave action causes consolidation of the breakwater and nesting of the stones, which increase the stability. Typically stones with a weight two to ten times smaller can be used for construction of the berm compared to the main armour layer of a conventional breakwater.

Especially when a quarry is available near the construction site and it is not possible to produce a sufficient quantity of large armour stones for a conventional rubble mound breakwater, a berm breakwater can be a feasible solution. Berm breakwaters are presently being considered for more and more applications worldwide, and several berm breakwaters are or have already been constructed. Berm breakwaters can normally be constructed with only two stone gradations as indicated in Figure 1. This reduces the activity of sorting stone material in the quarry. Proper design of berm breakwaters might lead to utilisation of almost 100 per cent of the quarry yield.

The smaller stones to be used for berm breakwaters have also an influence on the construction method and equipment to be used. The core can be constructed by end tipping trucks or dumping by barges, whereas the berm can be constructed by cranes with stone grabs, end tipping trucks or excavators. Generally lighter and less specialised construction equipment can be used compared to construction of conventional breakwaters. Even if the construction tolerances are wider for berm breakwaters than for conventional rubble mound breakwaters, fulfilment of the specifications to the stone material (mean weight, gradation, geometrical shape, quality, content of fines, etc), construction method and breakwater profiles is strictly required (Sørensen and Jensen (1990) and Jensen and Sørensen (1992)).

3 EXPERIENCE WITH BERM BREAKWATERS

Berm breakwaters have been designed and model tests have been performed for many projects, of which some have actually been constructed to date. This section describes eight examples of constructed berm breakwaters. In three cases, the profile development has been measured in prototype. In the following, H_s is the significant wave height, Δ is the relative stone density, $D_{n50} = (W_{50}/\rho_s)^{1/3}$ is the nominal diameter, W_{50} is the median weight, and ρ_s is the stone density.

3.1 Norwegian Experience

Two berm breakwaters have been constructed in Norway; one in Årviksand and one in Rennesøy. In order to reduce construction costs, both projects included a structural variant to the typical berm breakwater profile. These structural variants are further discussed in the following.

Årviksand

The berm breakwater constructed in Årviksand in northern Norway is an extension of a breakwater for a fishing port. In the design, a significant wave height of $H_s=6.5$ m and a water level of +3.6 m have been used.

Through model tests, it was found economical to use larger stones for the rear side of the breakwater to protect against wave overtopping rather than increasing the crest elevation or extending the berm width. The disadvantage of this solution is an additional stone class to be handled in the quarry. A typical profile of the trunk section including a strengthened rear side is shown in Figure 3. Armour stones with a median weight of 4.4 t was used for the berm, which results in a stability parameter of $H_s/\Delta D_{n50}=3.4$. The breakwater head was also constructed of stones with an average weight of 4.4 t, but the upper part was armoured with 8 to 14 t stones and the top elevation of the berm increased from +3.6 m to +4.5 m, as shown in Figure 4.

After construction the armour profile has been monitored and new monitoring will be made after major storms in which reshaping of the breakwater has occurred. Fifty of the armour stones have been marked and it is the plan to track their movements after reshaping has taken place. The monitoring of the berm breakwater in Årviksand and similar monitorings of the breakwater in Rennesøy will give valuable prototype experience on profile development.

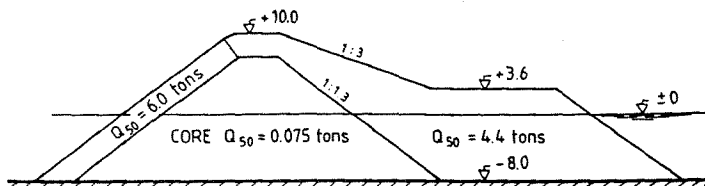

Figure 3 Extension of breakwater at Årviksand, profile of breakwater trunk section (Figure from Tørum et al (1990)). All measures are in metres.

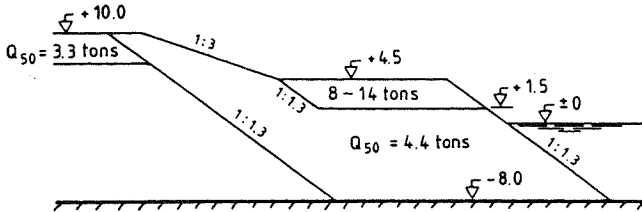

Figure 4 Extension of breakwater at Årviksand, profile of breakwater head, (Figure from Tørum et al (1990)). All measures are in metres.

Rennesøy

A new ferry terminal has been constructed on Rennesøy with a berm breakwater protecting the harbour facilities (Espedal and Lothe (1994)). From an economical point of view it was desirable to extend the core (0-1.5 t stones) into the berm to make better use of the quarry yield. Based on results from model tests, the profile shown in Figure 5 was selected for the most exposed parts of the trunk, whereas the roundhead was designed with larger stones on the top of the berm and without extension of the core into the berm. In the design, a significant wave height of approximately $H_s = 7.0$ m was used and the stability parameter for the trunk section has accordingly been assessed to $H_s/\Delta D_{n50} = 3.3$.

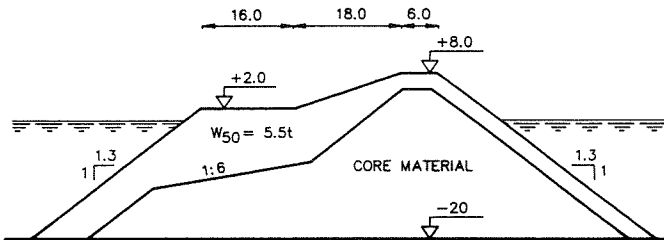

Figure 5 Typical cross-section for berm breakwater on Rennesøy. All measures are in metres.

This structural variant may in many cases be economical due to substitution of berm stones by cheaper core material. The disadvantage of this substitution is lower energy dissipation in the porous berm material and therefore reduced stability of the berm stones.

The berm was constructed using an excavator with a hydraulic hand. One by one, the quarry stones were dropped or thrown to the right position in the breakwater. Special attention was paid to quality control during construction in order to ensure the long-term stability of the berm breakwater. Examples of the established demands are (see Espedal and Lothe (1994)):

- Not accept stones with a mass less than 1.0 t for the berm, whereas no upper restriction was given.
- All stones for the berm were weighed, and control of the mean weight was made for samples of 200 t.

- The quarry stones should be clean and have no fissures, and restrictions to the shape were made in order to avoid flat stones (the height to width ratio should not exceed 3:1).
- For each 30,000 cubic metres of stone material, it was checked that the density at least was 2.7 t/m³.
- The core material was specified to range from 0 to 1.5 t, but no top soil, clay, silt or sand was allowed.
- Continuous surveying of the breakwater was made during construction in order to ensure the correct geometry of all parts of the breakwater (including the transition from one to another stone class). Permission to continue construction was given when it was proven that the given demands to acceptable geometrical deviations were fulfilled.

3.2 Icelandic Experience

Since 1983, seventeen rubble mound structures of the berm type have been constructed in Iceland. Ten of these were new structures, whereas the others were reinforcements or repairs of existing breakwaters in the form of additional protection on the seaside of old caisson breakwaters or modifications of existing conventional breakwaters. Presently, four berm breakwaters are planned or under construction in Iceland.

The main problem facing construction of rubble mound breakwaters in Iceland is the poor quality of the stones (basalt) and the often associated lack of sufficiently large armour stones. This can be exemplified by results from an inspection of a rubble mound structure built in 1968-69 in one of the most exposed locations in Iceland (Vopnafjörður). The armour layer of the breakwater was originally constructed from stones of 10 to 15 t. An inspection showed that abrasion and splitting of stones had caused deterioration of the breakwater. Weathering took place above the water level, and the estimated loss in diameter was 0.5 to 1.0 cm per year in a 20 year period. This corresponds to a weight loss of 1.8 to 3.4 t for a 10 t stone. This severe problem with abrasion and splitting of stones in Iceland is normally treated by using stones with reduced size in the model tests.

Sigurdarson and Viggosson (1994) mention that a high utilisation of quarried rocks can be achieved by construction of berm breakwaters, and that this is of great importance in Iceland where shortage of sufficiently large armour stones is a problem. The berm breakwaters in Iceland often consist of several stone classes, with the largest stones used for singular points and as a protecting layer on the berm and crest. The sorting of quarry stones is only increased marginally as all stones are weighed as part of the handling in the quarry. The application of the largest stones for the most exposed parts of the berm breakwaters makes the profiles more stable and/or results in a high utilisation of the quarry output. This means that it is of great importance to obtain knowledge of the distribution of the quarry yield in an early stage of the design phase.

In addition to the normally stated advantages of berm breakwaters, two other factors are mentioned by Viggosson (1990): Local contractors with no special experience in marine work can be used as the construction can be made with available land based equipment and the tolerances for placement of stones are eased. Shortage of funds often makes it necessary to extend the construction period over two summers with a stop in the winter season (experience in Iceland indicates that a partially completed berm breakwater functions well through the storms of one winter, and repairs are much easier than for a conventional breakwater).

Sigurdarson and Viggosson (1994) state that a comprehensive quality assurance programme is necessary during the construction of berm breakwaters to ensure that the armour stones fulfil the requirements of quality and durability. They propose that a quality assurance programme includes:

- grading, weight requirements, specific gravity, and water absorption compatible with the design criteria
- visible inspection for defects, joints, aspect ratio and colour index

Bakkafjordur

The first berm breakwater in Iceland was built in 1983-84 at Bakkafjordur. The 50 years design wave condition is $H_s=4.8$ m and $T_p=12.0$ s for a design water level of +2.5 m. The berm consists of stones in the range from 2.0 to 6.0 t with an average weight of 3.0 t. The stability parameter has been calculated at $H_s/\Delta D_{n50}=2.9$. A typical cross-section of the constructed berm breakwater is shown in **Figure 6** together with comparisons of prototype measurements and results from model tests. Reasonable agreement was found between the profile developments in model and prototype. The possible rounding and breakage of the available poor quality stones was included in the model study by testing with reduced stone size. In nature, some deterioration of stones has been observed at the breakwater head.

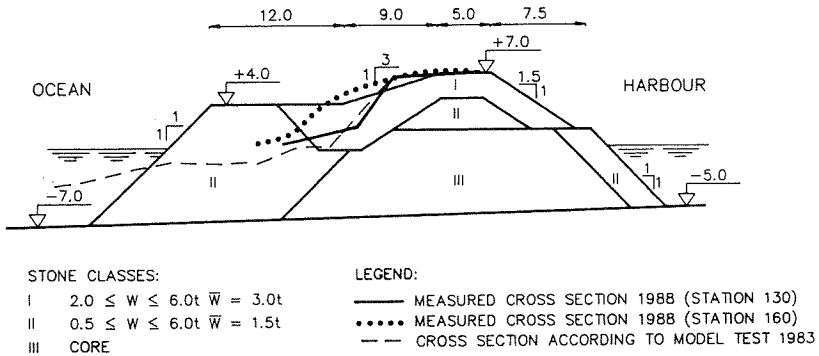

Figure 6 Measurements of profile reshaping of berm breakwater at Bakkafjordur (based on figures from Viggoisson (1990)). All measures are in metres.

Keflavik (Helguvik)

The berm breakwater project at Keflavik was described by Baird (1987). A typical cross-section of the breakwater is shown in **Figure 7**. The 50 year design wave condition is $H_s=5.8$ m and $T_p=9.6$ s with an angle of incidence equal to 45° , and a corresponding design water level of +5.0 m. The berm consists of 1.7 to 7.0 t stones with an average weight of 3.2 to 4.2 t, and the stability parameter has been calculated at $H_s/\Delta D_{n50}=3.2-3.5$. In the model tests, smaller stones were used in order to take into account possible deterioration of the stones.

3.3 Skopun, Faroe Islands

Presently, a berm type breakwater is being constructed in Skopun with the aim of reducing the wave overtopping at the existing harbour and for protection of a reclamation. The design conditions corresponding to a return period of 50 years are $H_s=5.8$ m and $T_p=18$ s. The design water level is about +1.0 m. A typical cross-section of the berm breakwater consisting of several

stone gradations is shown in **Figure 8**. The small berm is constructed of stones ranging from 5.5 to 12.5 t, with an average stone weight of about 8.3 t. With a stone density of 2.65 t/m³, the stability parameter has been calculated at $H_s/\Delta D_{n50}=2.5$. Three-dimensional model tests have been carried out as part of the design, and the reshaped profile of the most exposed section of the breakwater is shown in **Figure 9**.

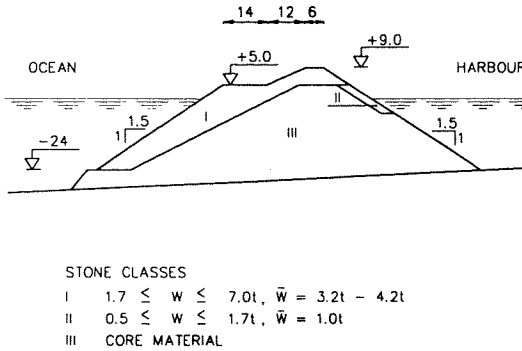

Figure 7 Cross-section of a berm breakwater at Keflavik. (Based on figure from Baird (1987)). All measures are in metres.

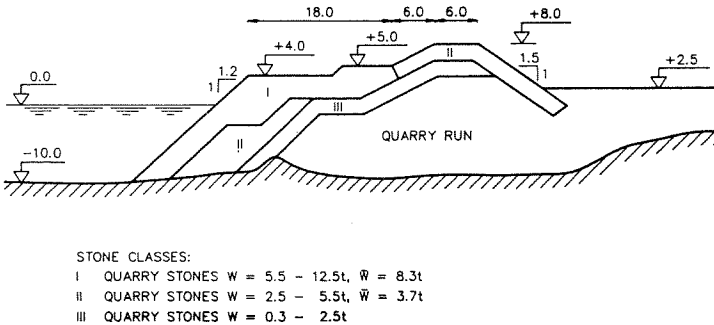

Figure 8 Typical profile for Skopun harbour (presently under construction). All measures are in metres.

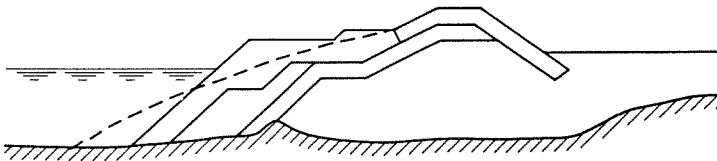

Figure 9 Reshaped profile after exposure to the design wave conditions (results from model tests). All measures are in metres.

3.4 Hay Point, Australia

For protection of a tug boat harbour, a berm breakwater has been model tested and constructed as described by Bremner et al (1987). Numerical wave modelling has revealed a 100 years significant wave height of $H_s=5.0$ m and a corresponding peak period of $T_p=7$ s, and a design water level of +4.5 m. The stones used for the berm has a weight of 4.0 to 7.0 t with an estimated average weight of 5.3 t. Applying a stone density of 2.65 t/m^3 , the stability parameter can be assessed at $H_s/\Delta D_{n50}=2.5$. A typical profile of the designed berm breakwater is shown in **Figure 10**.

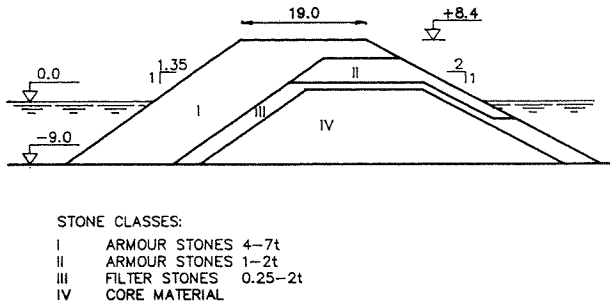

Figure 10 Typical cross-section for a berm breakwater at Hay Point. (Based on figure from Bremner et al (1987)). All measures are in metres.

3.5 St George, Alaska, USA

A berm breakwater project on St George Island has been described by Gilman (1987). The concept profile for this breakwater was developed through model tests performed at the Danish Hydraulic Institute. The design wave condition is $H_s=10.4$ m offshore (and about 6.4 m in front of the breakwater) and $T_p=18.0$ s. The harbour layout is shown in **Figure 11**, and a typical cross-section of the roundhead in **Figure 12**. The berm for the breakwater roundhead had a top elevation of 16 feet (4.9 m) and a width of 61 feet (18.6 m), and the berm for the trunk section had a top elevation of 12 feet (3.7 m) and a width of 55 feet (16.8 m). The berm of both the trunk and roundhead was constructed of stones with a weight from 1.5 to 9.0 t. The average stone weight is about 4.8 t, and the stability parameter is calculated at $H_s/\Delta D_{n50}=3.3$.

Before completion of the breakwater, construction was shut down in late 1986 with the North breakwater roundhead only half completed (30 ft of the horizontal berm was constructed, none of which rose above elevation +12 ft). During the winter of 1986-87, storms occurred which approached the design storm in intensity. Surveys of the breakwater profiles were made before and after the winter storms, showing only minor changes in the profiles. This indicates that the incomplete berm breakwater performed well during these severe wave conditions (see Gilman (1987)).

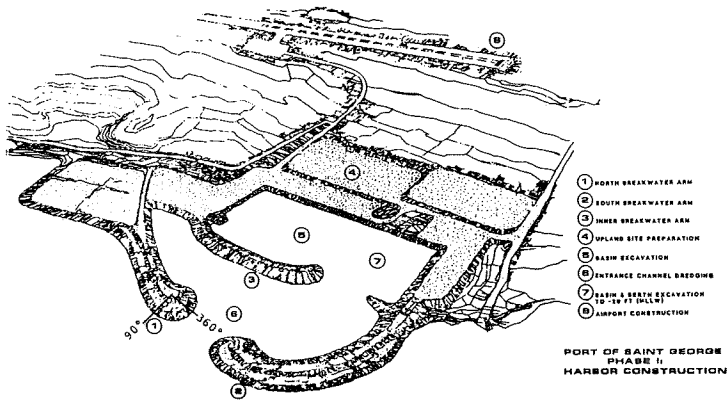

Figure 11 Harbour layout for St George. (Figure from Gilman (1987)).

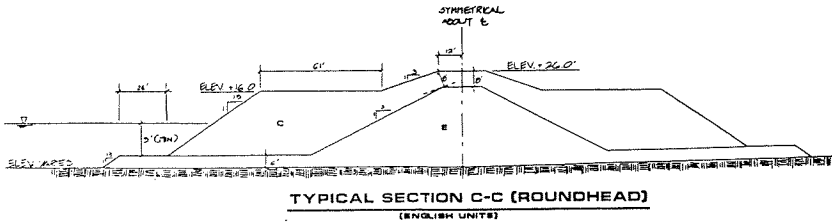

Figure 12 Typical cross-section of berm breakwater roundhead for St George. (Figure from Gilman (1987)). All measures are in feet.

3.6 Racine, Wisconsin, USA

The implementation and performance of a berm breakwater design at Racine, Western shore of Lake Michigan, has been described by Montgomery et al (1987). The design conditions, corresponding to a return period of 20 years, are a significant wave height of $H_s = 4.4$ m, a significant wave period of $T_s = 10.0$ s and a water level of +1.4 m relative to low water datum. The water depth in front of the breakwater is 6-8 m and a typical cross-section is shown in Figure 13. The width of the berm is 12.2 m at the trunk and 15.2 m at the roundhead. Stones with a weight in the range 0.14 to 3.6 t have been used, which with an average weight of 0.82 t gives a stability parameter of $H_s/\Delta D_{n50} = 4.1$.

After construction, the berm breakwater was levelled and found to be in good agreement with the design. The breakwater was completed in the Autumn of 1986 and was in February and March 1987 exposed to two major storms, which approximated the design conditions. A description of the breakwater performance is summarised below (see Montgomery et al (1987)).

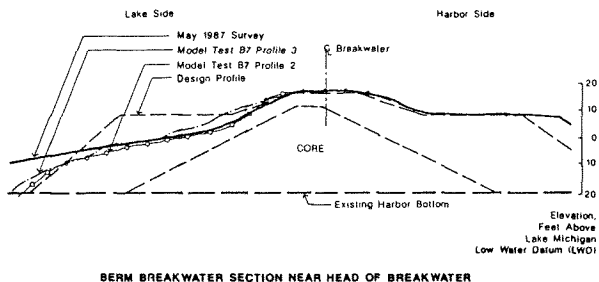
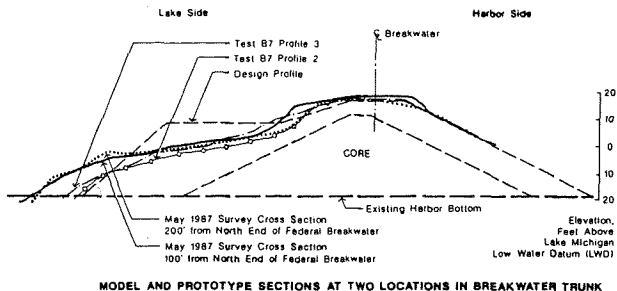

Figure 13 Comparison of model tests and prototype measurements. (Figures from Montgomery et al (1987)). All measures are in feet.

Visual, underwater and survey assessments of the berm breakwater were performed after the March storm with the following main observations:

- the berm was reshaped so that it was generally below water along the trunk section, whereas parts of the roundhead was less reshaped
- small rounded cobbles (diameter of 15 to 45 cm) were observed at the water line, indicating breakage of some of the berm stones
- some of the berm stones had moved towards the crest
- the reshaped berm had a typical slope between 1:6 to 1:10
- no evidence of substantial overtopping was observed as the rear side appeared unaffected

A subsequent survey was conducted and indicated that despite the fairly dramatic change in the above-water appearance, the berm breakwater appeared to have behaved similarly to the model tests with respect to berm reshaping. Survey cross-sections and profiles from the modelling study are presented in Figure 13. A fine agreement was found between the reshaped profiles measured during model testing and in prototype.

4 SUMMARY OF BREAKWATER EXAMPLES

A summary of selected geometrical, wave and stone size data for the presented breakwaters is listed in Table 1.

Table 1 Summary of the data for the described examples of constructed berm breakwaters.

Location	h^* (m)	R_c^{**} (m)	H_s (s)	T_p (s)	W (t)	W_{50} (t)	D_{n50} (m)	$H_s/\Delta D_{n50}$	R_c/H_s
Årviksand	11.6	6.4	6.5	~14.0	-	4.4	1.18	3.4	0.98
Rennesøy	-	-	7.0	-	-	5.5	1.28	3.3	-
Bakkafjörður	10.5	4.5	4.8	12.0	2.0-6.0	3.0	1.05	2.9	0.94
Keflavik	29.0	4.0	5.8	9.6	1.7-7.0	3.2-4.2	1.07-1.17	3.2-3.5	0.69
Skopun	11.0	7.0	5.8	18.0	5.5-12.5	8.3	1.46	2.5	1.20
Hay Point	13.5	3.9	5.0	7.0	4.0-7.0	5.3	1.26	2.5	0.78
St George	8.2	6.4	6.4	18.0	1.5-9.0	4.8	1.22	3.3	1.00
Racine	9.8	3.5	4.4	~10.6	0.14-3.6	0.82	0.68	4.1	0.80

Note: * h is the water depth in front of the structure in the design situation
 ** R_c is the freeboard, ie the vertical distance from the actual water level to the crest

The listed parameters should be regarded with caution as some of the data are uncertain. For example, it is rarely indicated in the literature if the wave heights refer to offshore or nearshore conditions.

The practical experience with the berm breakwaters described in the present paper shows that the dimensionless stability parameter, $H_s/\Delta D_{n50}$, is in the range from 2.5 to 4.1. The Icelandic experience from 15 berm breakwaters shows a stability parameter in the range from 2.4 to 3.2 for breakwater trunk sections and in the range of 1.7 to 2.4 for breakwater roundheads where traditionally the largest quarry stones were applied. These values of the stability parameter are in the lower end of the classification of breakwaters made by Van der Meer (1988) quoting: $H_s/\Delta D_{n50}=3-6$ for berm breakwaters and S-shaped profiles.

The ratio between the freeboard and the significant wave height, R_c/H_s , varies between 0.7 and 1.2, which is smaller than for conventional rubble mound breakwaters as the porous berm reduces wave run-up and overtopping. This range of dimensionless crest free board is found to agree well with results from a series of model tests carried out for studying the rear side stability of berm breakwaters (Andersen, Juhl and Sloth, 1992).

5 CONCLUSIONS

A berm breakwater is a rubble mound breakwater with a berm above still water on the seaward side, which under wave exposure reshapes into an equilibrium profile with a slope of approximately 1:5. Depending on the stability parameter the reshaped profile will be statically or dynamically stable, the latter indicating that the individual stones will move but the profile will be in equilibrium.

In summary, the most important advantages and drawbacks of berm breakwaters compared to conventional rubble mound breakwaters are:

- Smaller armour stones can be used for a berm breakwater (two to ten times smaller by weight), resulting in more quarries capable of supplying the required armour stones.

- Normally only two stone classes are required for construction of a berm breakwater, ie the small stones are used as core material and bed protection and the larger stones for the berm and armour layers on the crest and rear side. If well designed, the entire quarry output can be used. The Icelandic experience gives preference to berm breakwater profiles consisting of several stone classes, which allows to use the largest stones for the singular points and as a protecting layer on the berm and crest.
- The use of smaller stones implies that lighter equipment can be used for construction of berm breakwaters. Wider tolerances can be allowed during construction, giving the contractors the possibility of using end tipping trucks or excavators.
- For a berm breakwater built from two stone classes the stones used for protection of the rear side are relatively small, which means that only limited wave overtopping is acceptable. This leads to the need for a relative high crest elevation of berm breakwaters, or alternatively the introduction of larger stones on the rear side.
- For dynamically stable breakwaters, there is a danger of progressive damage due to oblique wave attack, particularly at the roundhead. Therefore, this type of structure can only be used in cases where continued maintenance is acceptable or for temporary structures. Further, durability of stones may particularly be a problem if frequent stone motions occur.
- The practical experience with berm breakwaters is limited; and the design basis should be improved, especially with respect to longshore transport and stability of singular points.
- Construction tolerances to the berm breakwaters are wider than for conventional breakwaters. However, fulfilment of specifications to stone material, construction method and breakwater profiles is strictly required.

From the above findings, it can be concluded that berm breakwaters for permanent structures should be designed to reshape into a statically stable profile, ie no continuous stone movements should be allowed.

The practical experience with the eight presented berm breakwaters shows that the dimensionless stability parameter, $H_s/\Delta D_{n50}$, varies between 2.5 and 4.1. In three of the eight presented cases, prototype measurements of the reshaped profile were made, and it was found that the berm breakwaters in question performed well during wave conditions approximating the design conditions. Further, in two of the cases good agreement for the reshaped profiles were found with measurements from model tests. The ration between the freeboard and the significant wave height, R_c/H_s , is found to vary between 0.7 and 1.2, which is smaller than normally found for conventional rubble mound breakwaters.

Norwegian experience with berm breakwaters has shown that structural variants as compared to the typical profile can be economically advantageous. Two variants have been studied and applied in practice, ie protection of the rear side by larger stones and substitution of a part of the berm stones with core material.

6 ACKNOWLEDGEMENTS

The present study was carried out as part of the research and technological development programme in the field of Marine Science and Technology (MAST I). The study was financed by the Commission of the European Communities, Directorate General for Science, Research and Development through contract 0032, G6-S, Coastal Structures and by The Danish Research Council.

7 REFERENCES

- Andersen, O H; Juhl, J, and Sloth, P (1992): *Rear side stability of berm breakwaters*. International Conference on Coastal Engineering, Venice, Italy.
- Baird, W F and Woodrow, K (1987): *The development of a design for a breakwater at Keflavik, Iceland*. Seminar on Berm Breakwaters: Unconventional Rubble-Mound Breakwaters, Ottawa, Canada.
- Bremner, W et al (1987): *The design and construction of a mass armoured breakwater at Hay Point, Australia*. Seminar on Berm Breakwaters: Unconventional Rubble-Mound Breakwaters, Ottawa, Canada.
- Espedal, T G, and Lothe, A E (1994): *The Mortavika breakwater - A harbour exposed to severe weather*. Strait Crossings, Ålesund, Norway.
- Gilman, J F (1987): *Performance of a berm roundhead in the St George breakwater system*. Seminar on Berm Breakwaters: Unconventional Rubble-Mound Breakwaters, Ottawa, Canada.
- Hall, K R (1987): *Experimental and historical verification of the performance of naturally armouring breakwaters*. Seminar on Berm Breakwaters: Unconventional Rubble-Mound Breakwaters, Ottawa, Canada.
- Jensen, O Juul and Sørensen, T (1987): *Hydraulic performance of berm breakwaters*. Seminar on Berm Breakwaters: Unconventional Rubble-Mound Breakwaters, Ottawa, Canada.
- Jensen, O Juul and Sørensen, T (1992): *Hydraulic performance of berm breakwater heads*. Journal of Hydraulic Research, Vol 29, No 6.
- Montgomery, R J; Hofmeister, G J and Baird, W F (1987): *Implementation and performance of berm breakwater design at Racine*. Seminar on Berm Breakwaters: Unconventional Rubble-Mound Breakwaters, Ottawa, Canada.
- Sigurdarson, S and Viggosson, G (1994): *Berm breakwaters in Iceland, practical experiences*. Hydro-Port'94, Yokosuka, Japan.
- Sørensen, T and Jensen, O Juul (1990): *St Paul Breakwater, Phase 1*. International Conference on Coastal Engineering, Delft, The Netherlands.
- Tørum, A et al (1990): *Årviksand fishing port, breakwater extension*. PIANC, Osaka, Japan.
- Van der Meer, J W (1988): *Rock slopes and gravel beaches under wave attack*. Ph.D. thesis, Delft University of Technology, The Netherlands.
- Viggosson, G (1990): *Rubble mound breakwaters in Iceland*. Journal of Coastal Research, Special Issue 7, pp 41-61.